

Homework Assignment #6

Reading Assignment:

Chapter 5 in Electric Circuits, 8th Edition by Nilsson (omit section 5.6)

Problem Assignment:

Note: Be sure to follow the required PROBLEM FORMAT for every assignment in this course.

- Chapter 5 problems: 2, 5, 6, 8, 12, 15, 18, 22, 36, 41
- Problems 2 and 3 shown on the next page

Selected Answers:

(Note: Answers have also been provided for many problems that were not assigned. A good way to study for a test is to work extra problems.)

- 5.5) a) $v_a = -400 \text{ mV}$ b) $v_o = -6.8 \text{ V}$ c) $i_a = 20 \text{ } \mu\text{A}$ d) $i_o = 111.67 \text{ } \mu\text{A}$
5.6) $i_L = -250 \text{ } \mu\text{A}$
5.12) c) $-7.5\text{V} < V_c < -1.5\text{V}$ (answer in text is incorrect)
5.22) a) $R_b = 4 \text{ k}\Omega$, $R_c = 2 \text{ k}\Omega$, $R_f = 120 \text{ k}\Omega$ b) $i_a = -250 \text{ } \mu\text{A}$, $i_b = 0$, $i_c = 250 \text{ } \mu\text{A}$
5.36) a) $i_a = -4.6 \text{ mA}$ b) $v_{\text{right}} = -750 \text{ mV}$
5.41) v_o versus t is shown below:

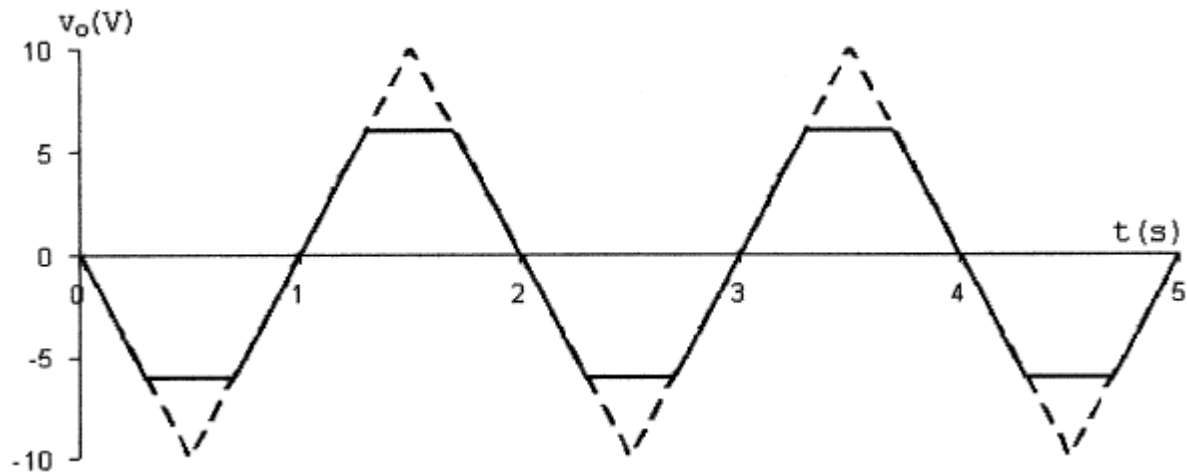

- $I_{o1} = -0.2 \text{ mA}$, $V_{o1} = -3.6 \text{ V}$ $I_{o2} = -1.189 \text{ mA}$, $V_{o2} = -4 \text{ V}$
- $I_o = -0.788 \text{ mA}$, $V_o = -2.065 \text{ V}$

2) Find V_{o1} , V_{o2} , I_{o1} , and I_{o2} in the circuit shown below.

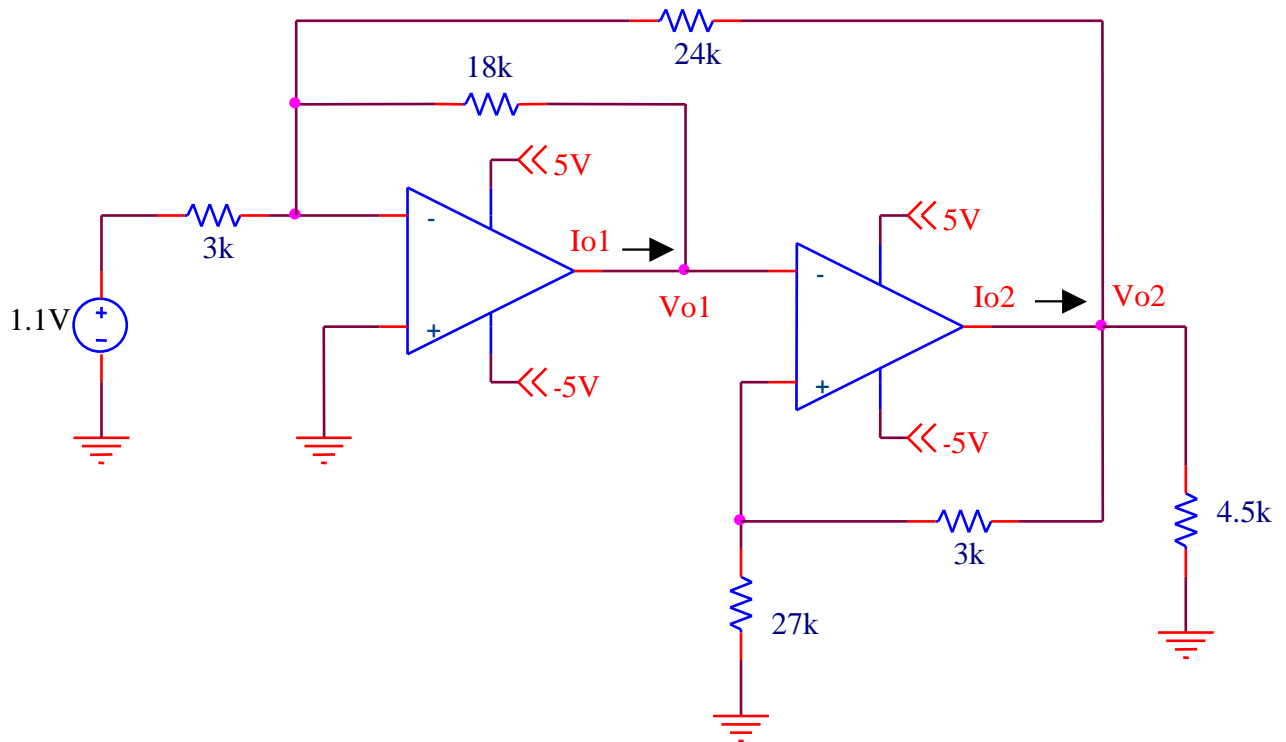

3) Find I_o and V_o in the circuit shown below.

