

PSPICE Assignment # 2

General Information:

- It is required that you use ORCAD Version 9.2 or later.
- Follow the guidelines illustrated in the “**PSPICE SAMPLE REPORT**” as you create your schematics and write your report.

Reference:

Read Chapters 1 - 3 in Schematic Capture Using Cadence PSPICE, 2nd Edition by Herniter
Handout: PSPICE Example - *Maximum Power Transfer (Varying a Component Value)*
Handout: PSPICE Example - *Op Amp Circuit using a Library Model (uA741)*
Handout: PSPICE Example - *Op Amp Example using a General Op Amp Model*

Assignment:

For each circuit, determine resistor values based on your EmplID as follows:

- Replace R1 by the first digit of your EmplID (in k Ω), R2 by the second digit (in k Ω), etc. If you have a 0 digit in your EmplID, use 10 k Ω instead of 0 k Ω .
- For example, if your EmplID is 2302613, then R1 = 2 k Ω , R2 = 3 k Ω , R3 = 10 k Ω , etc.
- Be sure to add text to each schematic as required (see Sample Report).
- Be sure to add text to each graph as required (see Sample Report).

1. Using DC Sweep to vary a voltage source

- A) **Hand Analysis:** Analyze Circuit 1 by hand with $V_x = 25V$ to determine the currents I_1 , I_2 , I_3 , and I_4 . Use the analysis method of your choice. Neatly show all work.
- B) **PSPICE Analysis:** Use a DC Sweep analysis in PSPICE to vary V_x from 0 to 100V and to graph I_1 , I_2 , I_3 , and I_4 versus V_x . Use text in PROBE (PSPICE's graphing package) to label each current on the graph. Use cursors to locate and label the value of each current when $V_x = 25V$.
- C) **Discussion:** Compare the currents when $V_x = 25V$ from steps A and B above in a table (they should agree) and discuss the results.

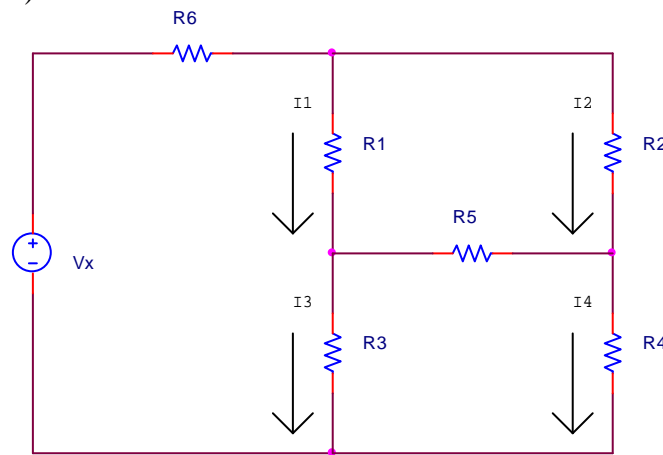

Circuit 1

2. Using DC Sweep to vary a current source

Examining Circuit 2 with superposition shows that the 100V source provides a downward current through R2 and the current source provides an upward current through R2. For some value of I_x , the two currents should cancel resulting in zero current through R2. PSPICE will be used to find the value of I_x where $I = 0$.

- A) **PSPICE Analysis:** Analyze Circuit 2 and use a DC Sweep analysis to vary the current source (you determine the range). Graph $I(R2)$ versus I_x and label the point where $I(R2) = 0$. (It may be necessary to zoom in on the point to get a more accurate value.)
- B) **Hand Analysis:** none required
- C) **Discussion:** List the value of I_x where I equals zero. Explain why $I(R2)$ positive on part of the graph and negative on the other part in terms of superposition.

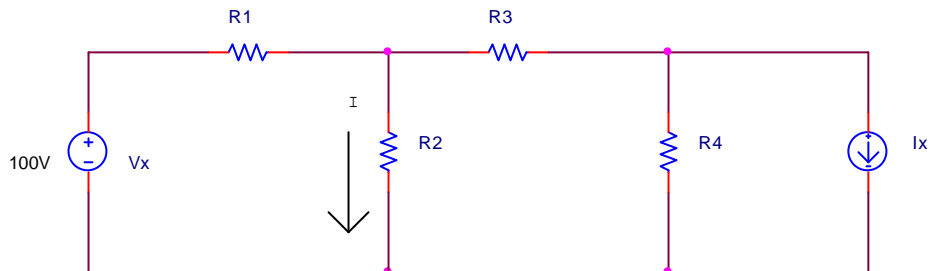

Circuit 2

3. Using DC Sweep to vary a resistance

- A) **Hand Analysis:** Resistors R1 through R5 in the circuit below form what is referred to as a “bridge circuit.” It can be shown that a bridge circuit is “balanced” when $R1 \cdot R4 = R2 \cdot R3$ and when the bridge circuit is balanced $I(R5)$ equals zero. Using resistor values based on your EmpliID for R1, R2, R3, R5, and R6, determine the value of R4 required such that the bridge in Circuit 3 is balanced.
- B) **PSPICE Analysis:** Analyze Circuit 3 with $V_x = 100V$ using a DC Sweep analysis in PSPICE to vary R4 (use a variable resistor part and remember to change SET to 1 and to display the value on the schematic). Vary R4 from $0.1 \cdot$ (the value determined in part A) to $10 \cdot$ (the value determined in part A) using 50 points per decade. Graph $I(R5)$ versus R4 and mark the point where $I(R5) = 0$. The value of R4 at this point should match the value found in step A.
- C) **Discussion:** Compare the results of steps A and B in a table and discuss the results.

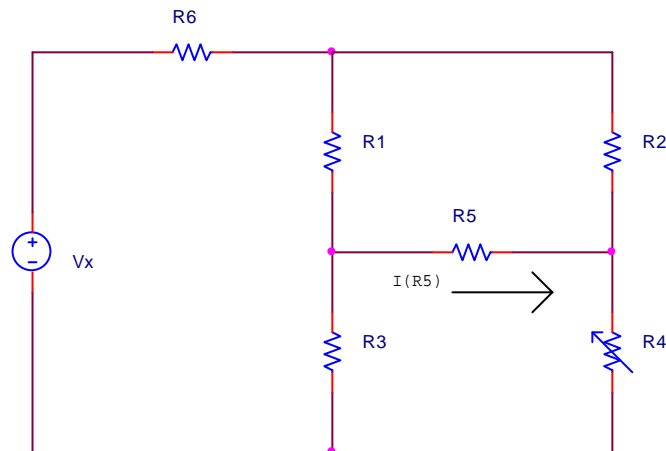

Circuit 3

4. **Maximum Power Transfer**

Let V_{123} = the 1st three non-zero digits of your EmplID in volts and I_{789} = the last 3 non-zero digits of your EmplID in mA. For example, if your EmplID is 2302613, then $V_{123} = 232\text{V}$, and $I_{789} = 613\text{ mA}$.

- A) **Hand Analysis:** Analyze Circuit 4 by hand in order to determine the value of R_L such that maximum power is delivered to R_L and to determine the value of maximum power that is delivered to R_L .
- B) **PSPICE Analysis:** Use PSPICE to analyze Circuit 4 where R_L varies from $0.1R_{Th}$ to $10R_{Th}$ using the value of R_{Th} determined in step A. Use at least 50 points per decade in the analysis. Plot P_L vs R_L with R_L on a log scale using PROBE (you can plot the function $V_L * V_L / R_L$). Place a cursor on the maximum point on this graph (use the PEAK function in PROBE) and mark the point. This point will correspond to R_{th} and P_{max} .
- C) **Discussion:** Compare the values of R_{th} and P_{max} determined in steps A and B in a table and discuss the results.

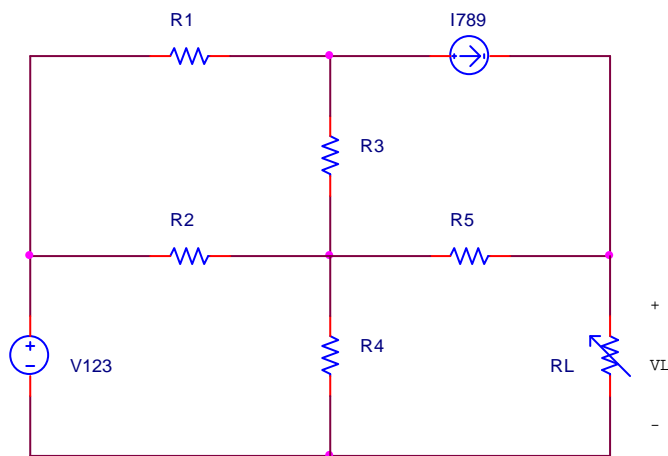

Circuit 4

5. **Operational Amplifiers**

- A) **Hand Analysis:** Analyze Circuit 5 **by hand** to determine the voltage V_o and the current I_o specified in the problem. Neatly show all calculations.
- B) **Analysis by PSPICE using a uA741 op amp:** Determine the voltage V_o and the current I_o in Circuit 2 using PSPICE with the op amp replaced by the uA741 op amp. Be sure to use a supply voltage large enough such that the op amp is not saturated. Use a voltage printer and a current printer to display the values of V_o and I_o .
- C) **Analysis by PSPICE using an op amp model consisting of a resistor and a dependent source:** Determine voltage V_o and the current I_o in Circuit 5 using PSPICE with the op amp replaced by the general op amp model (i.e., a voltage-controlled voltage source and a huge resistor). Use a voltage printer and a current printer to display the values of V_o and I_o .
- D) **Comparison:** Compare the results of steps B, C, and D in a table and discuss the results. Be sure to discuss how you determine the values of the supply voltages in part B.

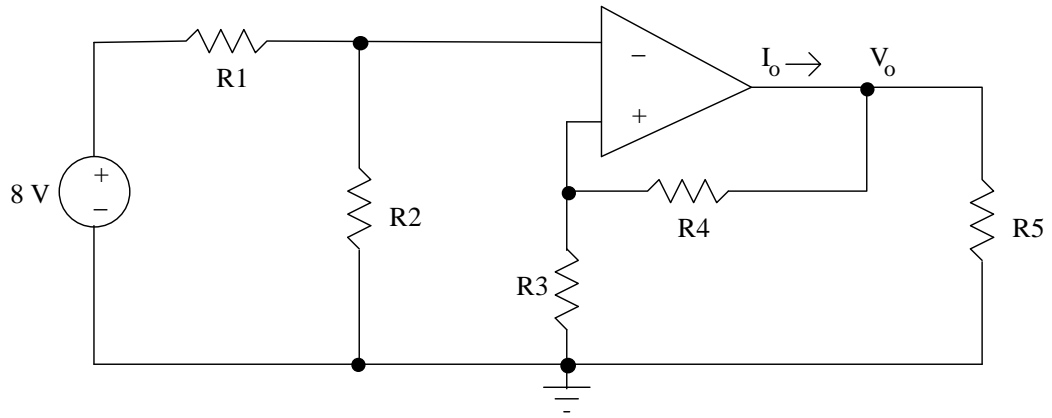

Circuit 5