

## Test #3 (Take-home test)

### Instructions:

1. This is an open-book, open-notes test. Any books are allowable.
2. The test must be your own work. You may neither give nor receive help of any kind from any person. Note that if two student's solutions look similar the instructor will investigate. If it appears that the students collaborated, both students will receive a grade of 0 for the test.
3. Work the test on separate paper.
4. Problems should be presented neatly with clear solutions.
5. Staple the solution sheets together or place them in a folder.
6. Include a final page with a signed pledge stating the following:  
**"I pledge that I have neither given help to any other person on this test nor received help from any other person on this test."**
7. The test will not be accepted late except in case of emergency (and timely notification).

### Test Problems:

1. (16 points) Consider the transfer function  $H(s)$  shown below:

$$H(s) = \frac{100(s)}{(s + 500)(s + 2500)}$$

- A) Express  $H(j\omega)$  in standard form for drawing a Bode plot.
  - B) Plot the Bode straight-line approximation for the **log-magnitude (LM)** response of  $H(j\omega)$  over the range  $\omega = 10$  rad/s to  $\omega = 100$  krad/s using the 4-cycle semi-log graph paper provided. Label all slopes in dB/oct or dB/dec and all levels in dB.
  - C) Plot the Bode straight-line approximation **phase plot** (i.e.,  $\phi(\omega)$  vs.  $\omega$ ) for the transfer function shown below over the range  $\omega = 10$  rad/s to  $\omega = 100$  krad/s using the 4-cycle semi-log graph paper provided. Label all slopes in degrees/dec and all levels in degrees.
2. (16 points) Use Excel or MatLab to graph the **LM and phase plots** for  $H(s)$  in problem 1. The graphs should, of course, approximately match the graphs from problem 1.
    - The graphs must be *properly formatted*.
    - Use the range  $\omega = 10$  rad/s to  $\omega = 100$  krad/s with  $\omega$  on a log scale
    - Label the axes (variable name and units, reasonable numerical values)
    - Include a title on each graph.
    - Each graph should be approximately fill one 8.5 x 11 sheet of paper (landscape).
    - If MatLab is used, be sure to include the program as well as the graph. Comments in the program should show your name, the problem number, and the problem description.
    - If Excel is used, you **MUST** also print out the worksheet including your name, the problem number, the problem description and the table of values. Also type out the formulas used in the first line of each column so that it is clear how the values in the table were determined.

3. (18 points) The circuit below is a *bandpass filter*.

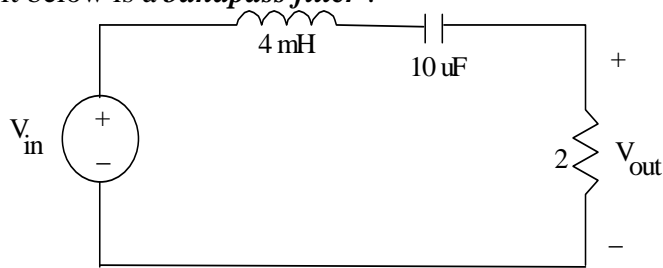

- A) Find  $H(s) = \frac{V_{out}(s)}{V_{in}(s)}$
- B) Determine the center frequency ( $\omega_0$ ) and the two cutoff (3 dB) frequencies ( $\omega_1$  and  $\omega_2$ ). Use these values to calculate the BW (in rad/s) and Q.
- C) Use impedance and frequency scaling to find new values for L and C in the circuit such that the new resistor value will be 1000 ohms and the new center frequency will be 40 krad/s
- D) Repeat steps A and B for the scaled circuit.

4. (18 points) Analyze problem 3 using PSPICE. Specifically:

- A) Perform an AC Sweep on the original circuit from 100 Hz to 100 kHz. Graph the LM of  $H(s)$ . Use cursors to mark  $f_0$ ,  $f_1$ , and  $f_2$ . Add text to the circuit and to the graph with your name, the course and the problem number. Also add text to the graph showing the values of BW and Q.
- B) Form a table comparing the values of  $f_0$ ,  $f_1$ ,  $f_2$ , BW, and Q from problems 3B and 4A.
- C) Repeat 4A using the scaled circuit from problem 3.
- D) Form a table comparing the values of  $f_0$ ,  $f_1$ ,  $f_2$ , BW, and Q from problems 3D and 4C.

5. (12 points) Consider the active filter circuit shown below.

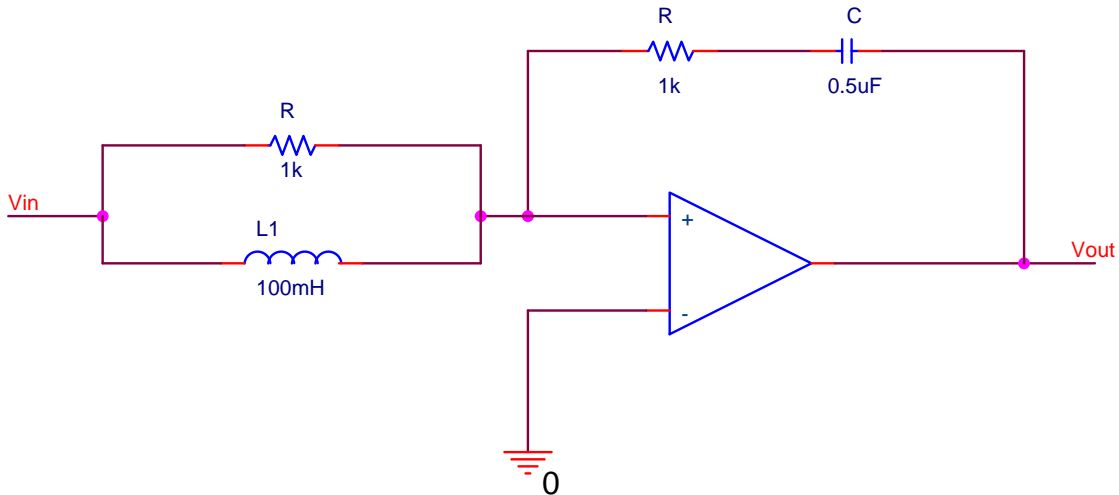

- A) Determine  $H(s) = \frac{V_{out}(s)}{V_{in}(s)}$
- B) Plot the Bode straight-line approximation for the **log-magnitude (LM)** response of  $H(j\omega)$  over and appropriate range of frequencies (4 decades) using 4-cycle semi-log graph paper. Label all slopes in dB/oct or dB/dec and all levels in dB.

6. (12 points) Consider the filter circuit shown below.

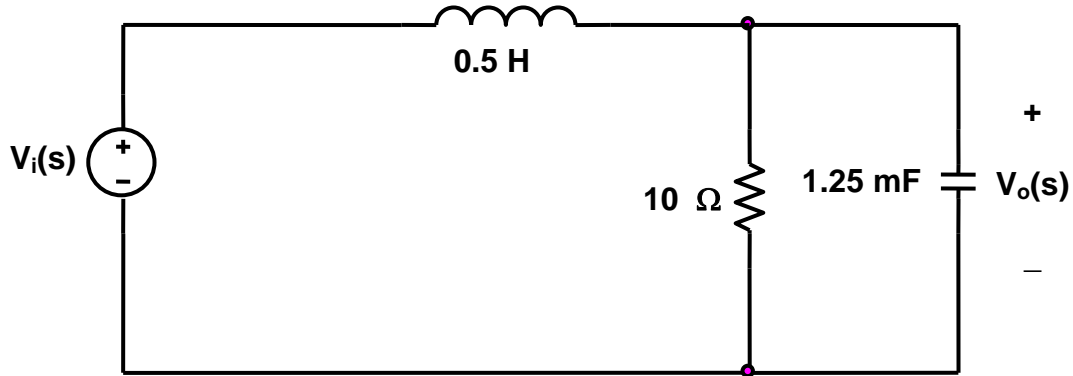

- A) Determine the transfer function,  $H(s) = V_o(s)/V_i(s)$ .
- B) What type (and order) of filter is this?

7. (8 points) Determine the transfer function,  $H(s)$ , corresponding to the following Bode log-magnitude plot (don't forget the constant).

