

## PSPICE Assignment #2

### Frequency Response of Circuits using PSPICE

#### General Information:

- It is required that you use ORCAD Capture 9.0 or later.
- Be sure to follow the example in the PSPICE Sample Report.
- The report that you turn in should reflect your own work for all PSPICE assignments. You may give other students limited assistance, but there should be absolutely no sharing of computer files. If two reports look too similar, the instructor will investigate and both students could receive grades of 0 for the assignment if evidence suggests that cheating was involved.

#### Reference:

Read Chapter 5 in Schematic Capture with Cadence PSPICE, by Herniter

*PSPICE Sample Report*

PSPICE Example: *Frequency Response (Log-Magnitude and Phase)*

#### Assignment:

##### 1. Frequency Response

A. Analyze Circuit 1 by hand to determine  $H_1(s) = \frac{V_C(s)}{V_{in}(s)}$  and  $H_2(s) = \frac{V_R(s)}{V_{in}(s)}$

where  $R$  = the last 4 non-zero digits of your EmplID in ohms. For example, if your EmplID is 8344056, then  $R = 4456$  ohms. Also show  $H_1(j\omega)$  and  $H_2(j\omega)$  in “standard form” for plotting Bode plots.

- B. Plot the Bode log-magnitude (LM) response and the phase response **by hand** using semi-log graph paper for  $H_1(j\omega)$  and  $H_2(j\omega)$  (use 4 separate sheets of graph paper). Plot frequency in Hz, not in rad/s. Begin your graph at least 1 decade before the break frequency and continue it until at least one decade after the break frequency (let your beginning and ending frequencies be powers of 10 in Hertz). Label all slopes and levels on the graphs appropriately. Label any break frequencies.
- C. Use PSPICE to generate separate graphs of the LM and phase responses for  $H_1(j\omega)$  and  $H_2(j\omega)$ . Use the same frequency range as in step 3B above. Place cursors at the 3 dB frequencies on each of the LM plots and mark the points.
- D. Compare the LM and phase plots produced in steps 1B and 1C. Be very specific as to how they are similar and how they differ. Were the differences expected? Include a table comparing the break frequencies (3dB frequencies) determined in steps 1B and 1C. What types of filters are represented by  $H_1(s)$  and  $H_2(s)$ ?

2. A. Graph the LM responses for  $H_1(s) = \frac{V_1(s)}{V_{in}(s)}$ . Measure the slope using two cursors (show them on the graph) and label the slope in dB/dec. Use a cursor to locate the break frequency and label it (recall that the break frequency is defined where the LM drops by  $3N$  dB, where  $N$  is the order of the filter). What type of filter is represented? List the filter type and order on the graph.
- B. Repeat step 2A for  $H_2(s) = \frac{V_2(s)}{V_{in}(s)}$ .
- C. Repeat step 2A for  $H_3(s) = \frac{V_3(s)}{V_{in}(s)}$ . Label the center frequency and both slopes. Find BW and Q.
- D. Repeat step 2A for  $H_4(s) = \frac{V_4(s)}{V_{in}(s)}$ . No breaks or slopes required, but specify the filter type.
- E. Derive expressions for  $H_1(s)$ ,  $H_2(s)$ ,  $H_3(s)$ , and  $H_4(s)$ .
- F. Use **frequency scaling** on Circuit 2 in order to change the cutoff frequency for  $H_1(s)$  to a value equal to the last 5 digits of your EmplID in Hertz. Also use **impedance scaling** such that the smallest resistor value is equal to the last 4 digits of your EmplID in ohms. For example, if your EmplID is 5260107, then scale the circuit for a cutoff frequency of 60,107 Hz and scale the smallest R value to 107 ohms. Repeat step 2A using the scaled circuit and verify that the new cutoff frequency is correct.
3. A) Determine the transfer function  $H(s) = V_o(s)/V_{in}(s)$  for Circuit 3 if  $C_1 = C_2 = 2.2$  nF,  $R_1 = 19$  k $\Omega$ , and  $R_2 = 900$   $\Omega$ .
- B) Draw the Bode log-magnitude (LM) plot for  $H(s)$  by hand using semi-log graph paper over the range 100 Hz to 1 MHz. Form the graph in Hz rather than in rad/s. Make a note of the two key break frequencies.
- C) Use PSPICE to generate the LM response over the range 100 Hz to 1 MHz. Place cursors at the two break points and mark the points.
- D) Compare the two break points found in parts B and C.

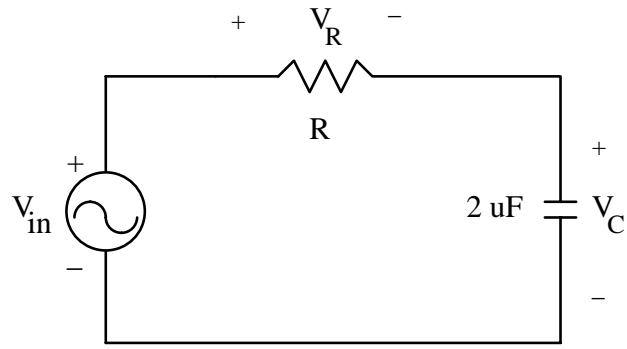

Circuit 1

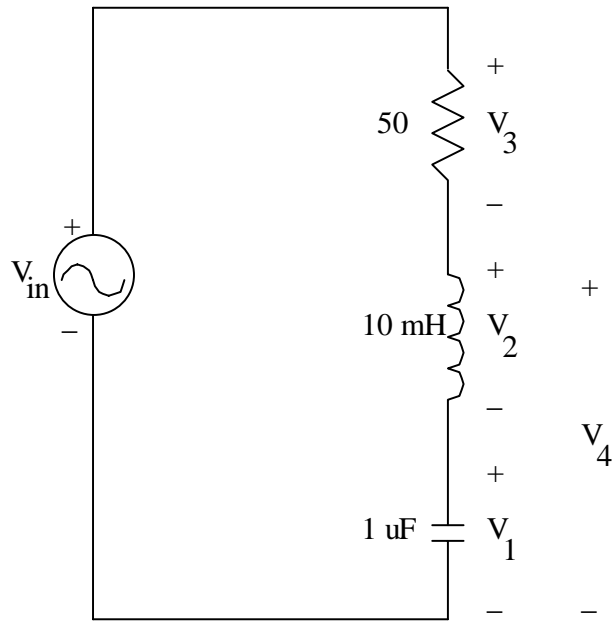

Circuit 2

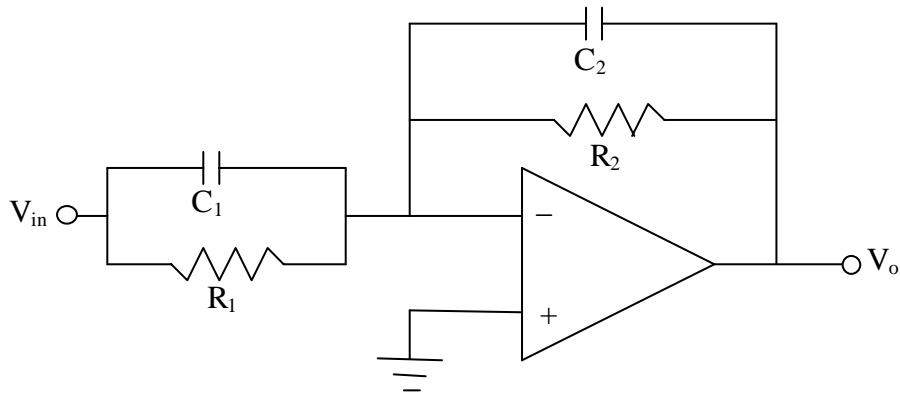

Circuit 3