

Team Assignment #6
Navigating the BOE-BOT with infrared sensors

Reading Assignment:

- 1) Refer to various sections in Robotics Version 2.2 (follow link on Paul Gordy's web page or online at www.parallax.com)
- 2) Refer to various sections of BASIC Stamp Syntax and Reference Manual, Version 2.1 for information of PBASIC commands (follow link on Paul Gordy's web page or online at www.parallax.com)
- 3) BOE-BOT Lecture #5 – Navigating the BOE-BOT with infrared sensors

Team Assignment:

- 1) Adding the infrared sensor module to the BOE-BOT
Follow the steps below (or check them if the infrared sensor module has already been added to your BOE-BOT):
 - Bolt the infrared sensor module to the front of the BOE-BOT using the two screws and nuts provided. Adjust the height of the sensors such that they are about 0.15" over the track surface.
 - Connect the red wires from each sensor module to Vdd (5V).
 - Connect the black wires from each sensor module to Vss (0V).
 - Connect the blue wire from the right sensor module to P1 and the blue wire from the left sensor module to P2 (you can use other inputs, but do not use P12 or P13 as they will be used by the servos).
- 2) Enter the infrared sensor navigation program from BOE-BOT Lecture #5
 - Be sure to add comments with the assignment number, team members names, BOE-BOT number, group number.
 - Also include comments for various commands in the program.
 - Modify the PULSOUT Duration values using data for your servos in order to make the BOE-BOT go straight, turn left, and turn right.
- 3) Navigating the track with infrared sensors
 - Test your BOE-BOT on the track (see the diagram on the following page). Adjust the program until the BOE-BOT can complete the course.
 - Make further adjustments such that your BOE-BOT will complete the course as quickly as possible.
 - Ask the instructor to time your BOE-BOT. The team with the fastest time will earn bonus points.

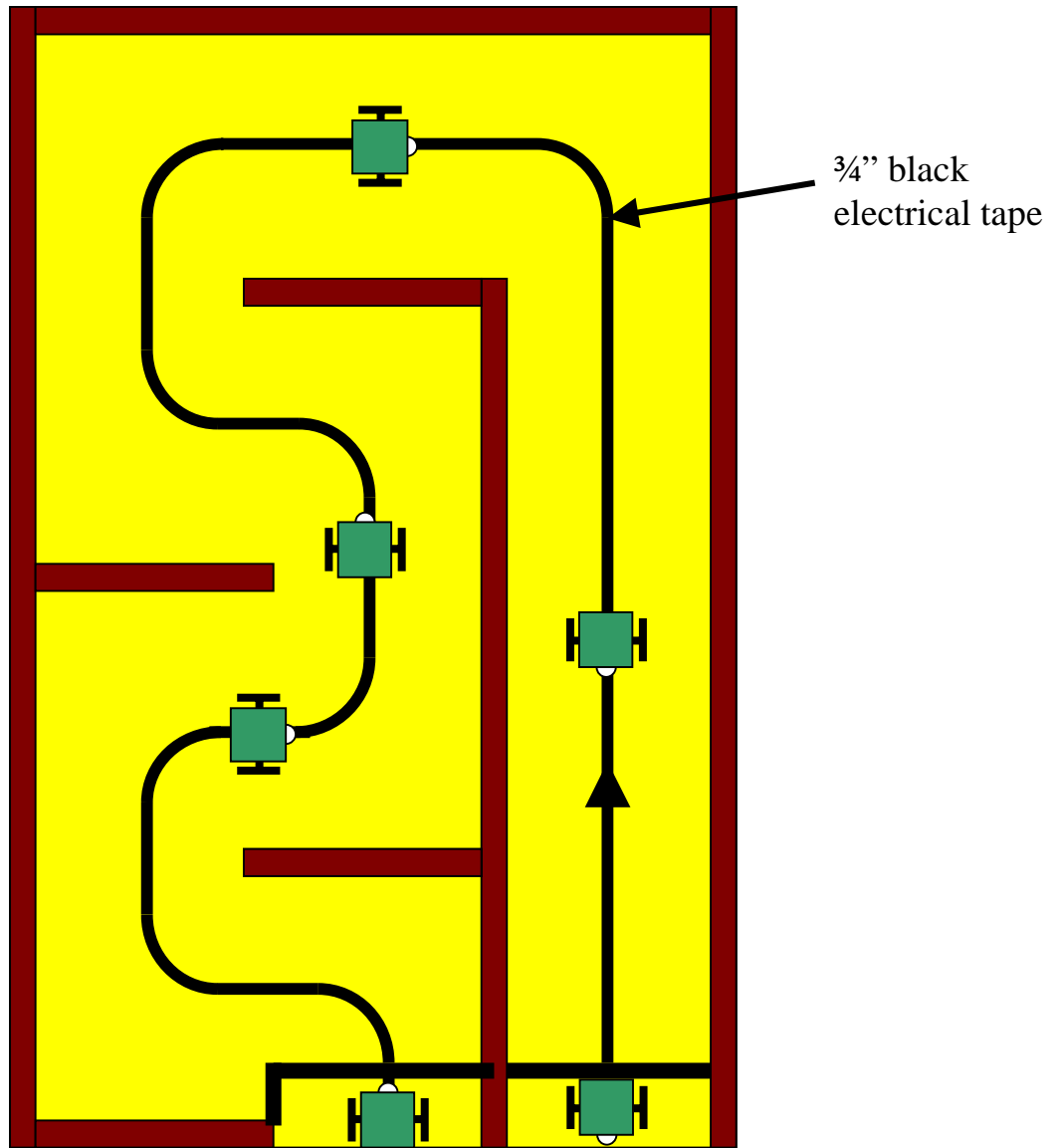

BOE-BOE Test Track

4) **Report**

Organize your results into a report and submit a single typed report for the group to the instructor by the assigned due date. The report should consist of:

- A) **Title page** - as shown below.
- B) **Printout** of the program used to navigate the course.
- C) **Discussion**. Include a substantial discussion section describing each method that your team has used to navigate the track (dead reckoning, whiskers, infrared sensors). For each method, discuss:
 - how difficult it was to complete the course (estimate how many times you had to modify the program)
 - how reliable the BOE-BOT was in completing the course using your final program
 - limitations to the method
 - ideas for improvements (how you might have been able to complete the course faster)

EGR 120
Introduction to Engineering
Team Assignment #6

Navigating the BOE-BOT using Infrared Sensors

Group #N (your group number)

Attendance & Participation Record:

(list all team members and all dates when teams worked together in class on this assignment and check boxes to mark attendance)

Team Member	Date 1	Date 2
John Doe	✓	✓
etc		

Demonstration of Programs

Program	Successfully Demonstrated	Time
Track Navigation	✓	Record time