

Operational Amplifier Circuit using a Library Model (uA741)

Purpose: Analysis of the op-amp circuit shown on the following page yields $V_o = -2V$. Use PSPICE to analyze the circuit using the uA741 op amp from the EVAL library.

Analysis: Since only the output node voltage V_o is needed, a bias point analysis will be used.

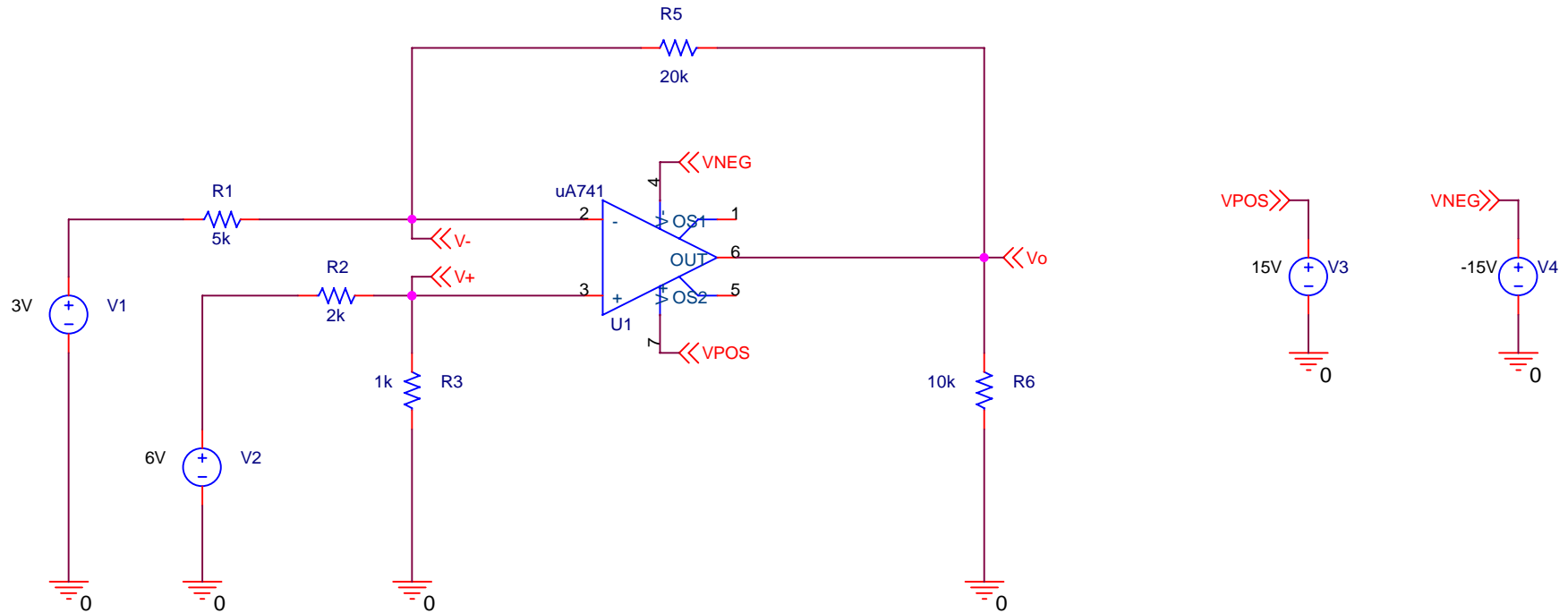

Notes:

- 1) Pins 1 and 5 on the uA741 op amp are unnecessary for this example.
- 2) OFFPAGE symbols were connected to the positive and negative supply voltage pins on the op amp instead of connecting the supplies VPOS and VNEG directly. This is not necessary, but is often convenient for simplifying schematics and for multi-page schematics.
- 3) The uA741 is a commonly available op amp. The professional version of ORCAD has an op amp library with hundreds of commercially-available op amps to choose from.

Title		
<Title>		
Size	Document Number	Rev
A	<Doc>	<RevCode>
Date:	Saturday, February 12, 2000	Sheet 1 of 1

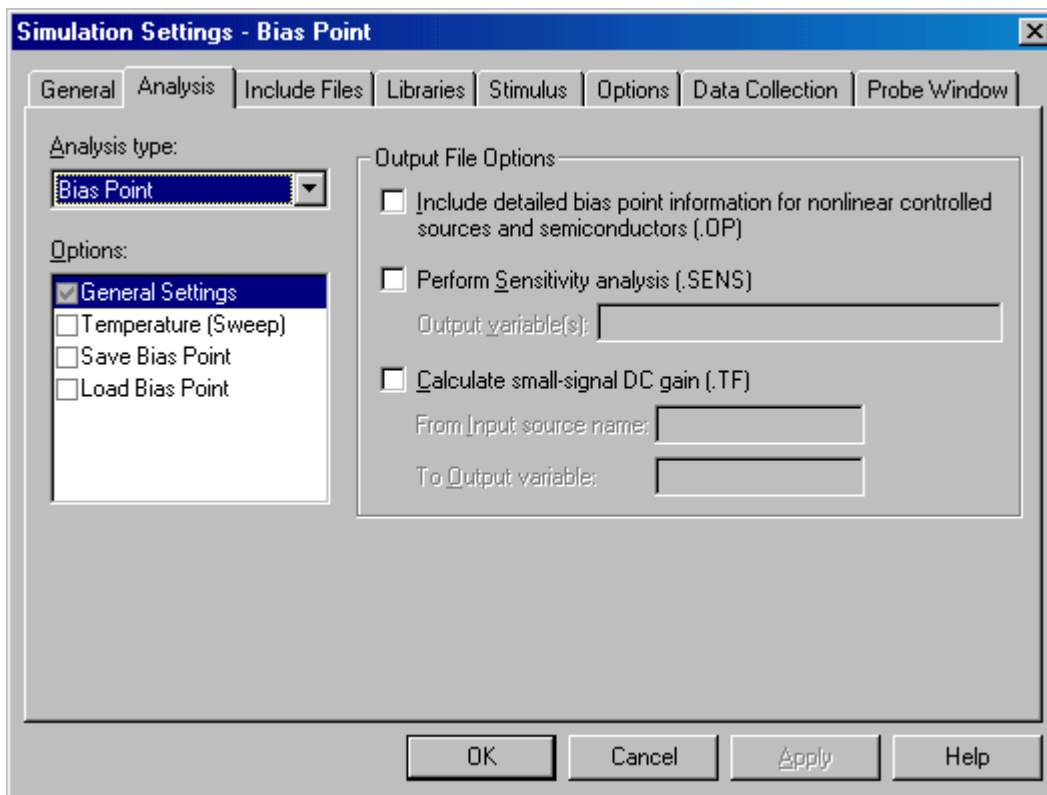
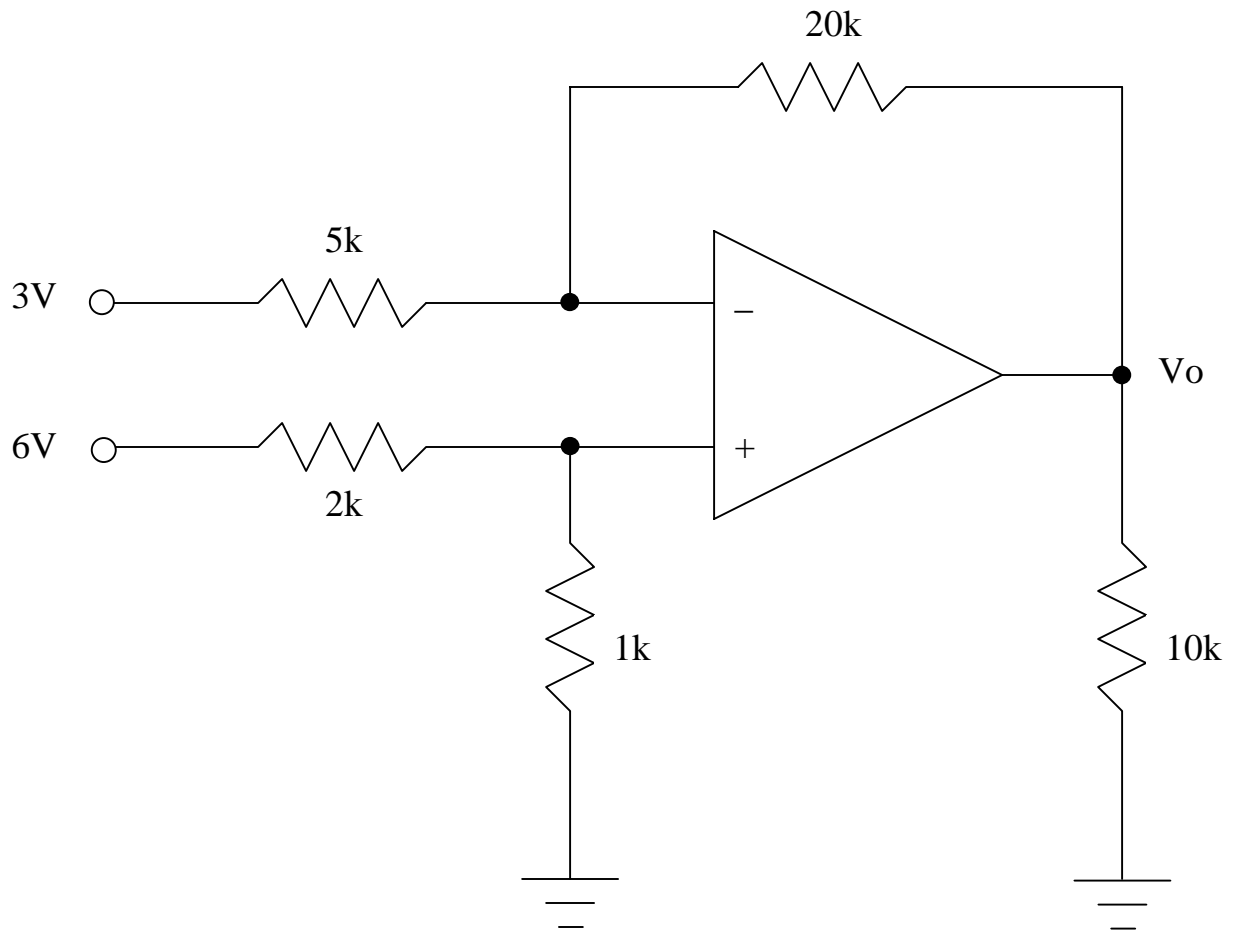

**** 02/12/ 19:40:58 ***** Evaluation PSpice (Mar 1999) *****

** circuit file for profile: Bias Point

**** CIRCUIT DESCRIPTION

** WARNING: THIS AUTOMATICALLY GENERATED FILE MAY BE OVERWRITTEN BY SUBSEQUENT PROFILES

*Libraries:

* Local Libraries :

* From [PSPICE NETLIST] section of pspiceev.ini file:

.lib nom.lib

*Analysis directives:

.PROBE

.INC "opamp741-SCHEMATIC1.net"

**** INCLUDING opamp741-SCHEMATIC1.net ****

* source OPAMP741

```

V_V2      N00117 0 DC 6V AC 1Vac
R_R1      N00123 V- 5k
R_R2      N00117 V+ 2k
R_R3      0 V+ 1k
R_R5      VO V- 20k
V_V1      N00123 0 DC 3V AC 1Vac
R_R6      0 VO 10k
X_U1      V+ V- VPOS VNEG VO uA741
V_V3      VPOS 0 DC 15V AC 1Vac
V_V4      VNEG 0 DC -15V AC 1Vac

```

.END

**** 02/12/ 19:40:58 ***** Evaluation PSpice (Mar 1999) *****

** circuit file for profile: Bias Point

**** SMALL SIGNAL BIAS SOLUTION TEMPERATURE = 27.000 DEG C

NODE	VOLTAGE	NODE	VOLTAGE	NODE	VOLTAGE	NODE	VOLTAGE
(V+)	1.9999	(V-)	1.9999	(VO)	-1.9988	(VNEG)	-15.0000
So Vo = -1.9988V							
(VPOS)	15.0000	(N00117)	6.0000	(N00123)	3.0000	(X_U1.6)	222.5E-06
(X_U1.7)	-2.1165	(X_U1.8)	-2.1165	(X_U1.9)	0.0000	(X_U1.10)	1.3919
(X_U1.11)	14.9600	(X_U1.12)	14.9600	(X_U1.13)	1.4059	(X_U1.14)	1.4059
(X_U1.53)	14.0000	(X_U1.54)	-14.0000	(X_U1.90)	-2.3529	(X_U1.91)	40.0000

(X_U1.92) -40.0000

(X_U1.99) 0.0000

VOLTAGE SOURCE CURRENTS
NAME CURRENT

V_V2	-2.000E-03
V_V1	-2.000E-04
V_V3	-1.667E-03
V_V4	1.667E-03
X_U1.vb	2.225E-09
X_U1.vc	1.600E-11
X_U1.ve	1.200E-11
X_U1.vlim	-2.353E-03
X_U1.vlp	-4.235E-11
X_U1.vln	-3.765E-11

TOTAL POWER DISSIPATION 6.26E-02 WATTS

JOB CONCLUDED

TOTAL JOB TIME .35