

Parametric and Transient Analysis of an RC Circuit

Purpose: Graph the capacitor voltage as the resistance varies from 1k to 10k in steps of 1k.

Analysis: A transient analysis from 0 to 5RC is performed using the largest value of R (10k). So $5RC = 5(10k)(1\mu F) = 50$ ms.

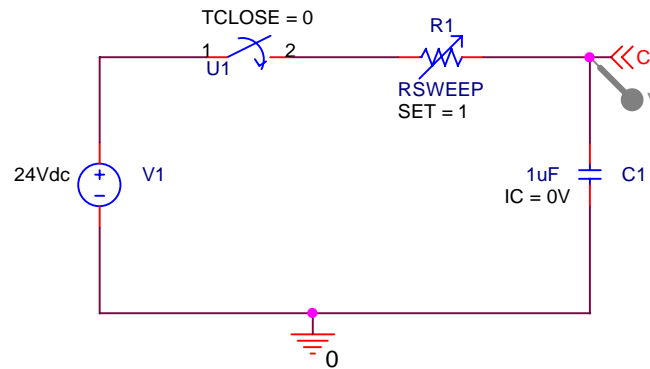

PARAMETERS:
RSWEEP = 1K

Place the part PARAM in the schematic from the SPECIAL library.

Edit the properties of PARAM and ADD a NEW property named RSWEEP (for example). Right-click on RSWEEP (while still in the property editor) and change the DISPLAY FORMAT so that both the name and the value will be displayed. Go back to the schematic and double-click on RSWEEP and give it the value 1K (for example).

Note that the part R_var from the ANALOG library was used for the variable resistor. A regular resistor (part R) would work as well.

Be sure to change the variable resistor's attribute SET to 1 or else the resistor values will be multiplied by the default SET value of 0.5.

An OFFPAGE symbol was used to label the node as C above the capacitor. A voltage marker was added so that V(C) will be automatically graphed after analysis.

The part Sw_tClose from the EVAL library was used to model the closing switch.

Title		
<Title>		
Size	Document Number	Rev
A	<Doc>	<RevCode>
Date:	Saturday, January 29, 2000	Sheet 1 of 1

