



2010 ASEE MODEL DESIGN COMPETITION

Sponsored by the Two Year College Division of ASEE

Date: June 18, 2009

Dear Colleague,

On behalf of the American Society for Engineering Education (ASEE) - Two Year College Division (TYCD), we invite you to encourage the submission of student design projects for the 12th Annual ASEE Lower Division MODEL DESIGN COMPETITION. This event will be held in conjunction with the 2010 ASEE Annual Convention, Louisville, Kentucky, June 20 - June 23, 2010. This competition is open to 2nd and 1st year students at four and two year colleges and universities.

In this year's competition student teams will design and build a baseball playing robot capable of shooting one ping-pong ball through each of three outfield targets and then traversing around the bases in the least amount of time. The robots must adhere to the guidelines of the model design competition (attached). An oral presentation and written report are included as part of the competition.

The main reason for this competition is for students to gain a better understanding of the design process from start to finish. Designing and building something from an idea is probably why they chose engineering in the first place. Use this design competition as a platform to reinforce their ideas and have some *engineering fun!* We hope to see you and your students' entries in Louisville.

Please find enclosed the guidelines and registration forms for this event. The interest and registration forms are on the back of this letter.

Sincerely,

Paul E. Gordy
Phone: 757-822-7175
Fax: 757-427-0327
Email: PGordy@tcc.edu

John Wadach
Phone: 585-292-2488
Email: JWADACH@monroecc.edu

Results from the
11th Annual ASEE Model Design Competition
June 5, 2009 - Austin, Texas

The ASEE Model Design Competition is a design/build competition for freshmen & sophomore engineering students at 2-year and 4-year colleges. The competition is held each year during the ASEE Annual Convention. The competition typically involves building an autonomous, battery-powered vehicle to navigate some sort of challenging track and/or complete some sort of task. The recent competition in Austin required robots to collect and sort 9 red and blue golf balls and then deposit them in the appropriate goal of a 6' x 8' track. Scoring for the competition was based on the number of balls deposited in the goal, the time to complete the task, and the points earned in the presentation phase of the competition.

15 teams competed and the results were as follows:

1st Place – Monroe Community College, Rochester, NY (Team: Tinkerballz)

2nd Place – Cedarville University, Cedarville, OH (Team: Jitterbug)

3rd Place – Monroe Community College, Rochester, NY (Team: Ball-e)

For complete results, including scores, pictures, videos, and more, visit the competition website at <http://www.tcc.edu/faculty/webpages/pgordy/ASEE/index.html>

Consider bringing a team from your college to next year's competition on June 28, 2009 in Vancouver, British Columbia. For more information or a copy of next year's rules, please contact Paul Gordy (Pgordy@tcc.edu, 757-822-7175) or John Wadach, Jwadach@monroecc.edu, 585-292-2488).



Group Photo of Teams and Robots

2010 ASEE MODEL DESIGN COMPETITION
Louisville, Kentucky
COMPETITION GUIDELINES

The American Society for Engineering Education (ASEE) Two-Year College Division (TYCD), Model Design Competition will be held Monday, June 21, 2010 in conjunction with the ASEE Annual Convention in Louisville, Kentucky.

Event Name: Baseball Bot

Objective:

To design and build an autonomous robot that is capable of shooting one ping-pong ball through each of three outfield targets and then rounding the bases in less than 60 seconds.

Track Specifications:

Figure 1: Isometric View of Track

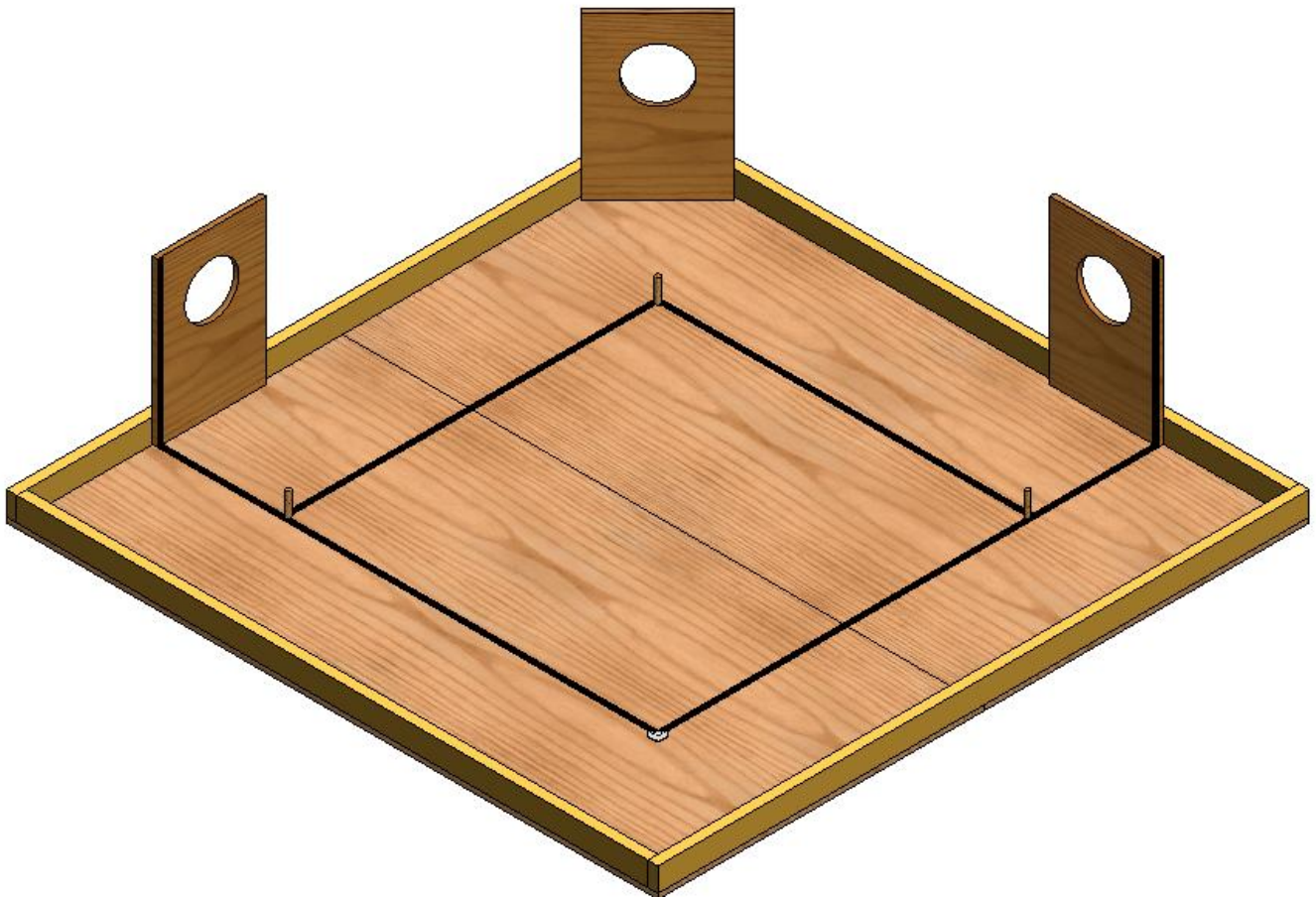
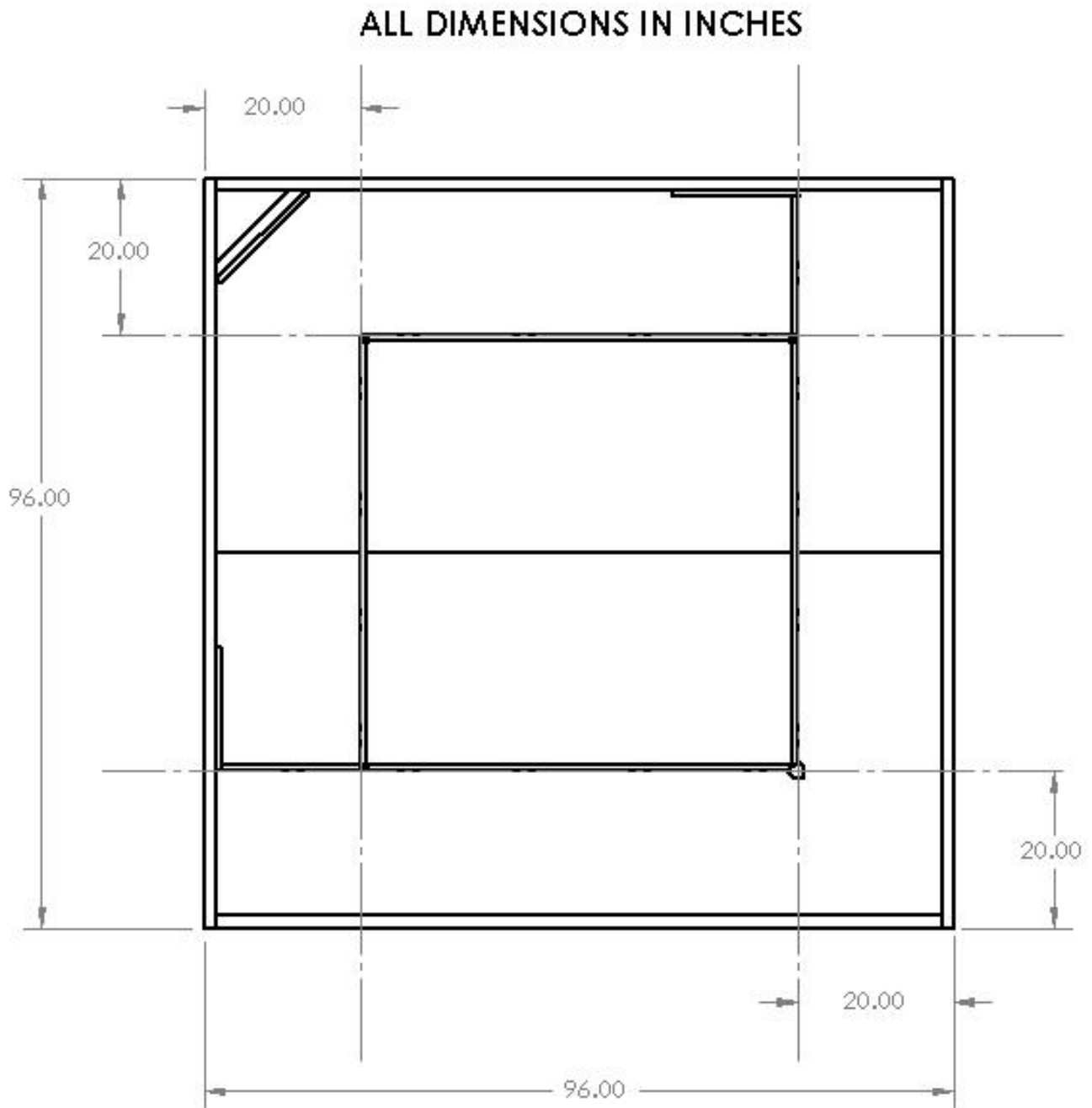

Figure 2: Top View of Track



All 20.00" dimensions are measured from the outside edge of the plywood to the outside edge of the tape.

Figure 3: Front View of Outfield Target

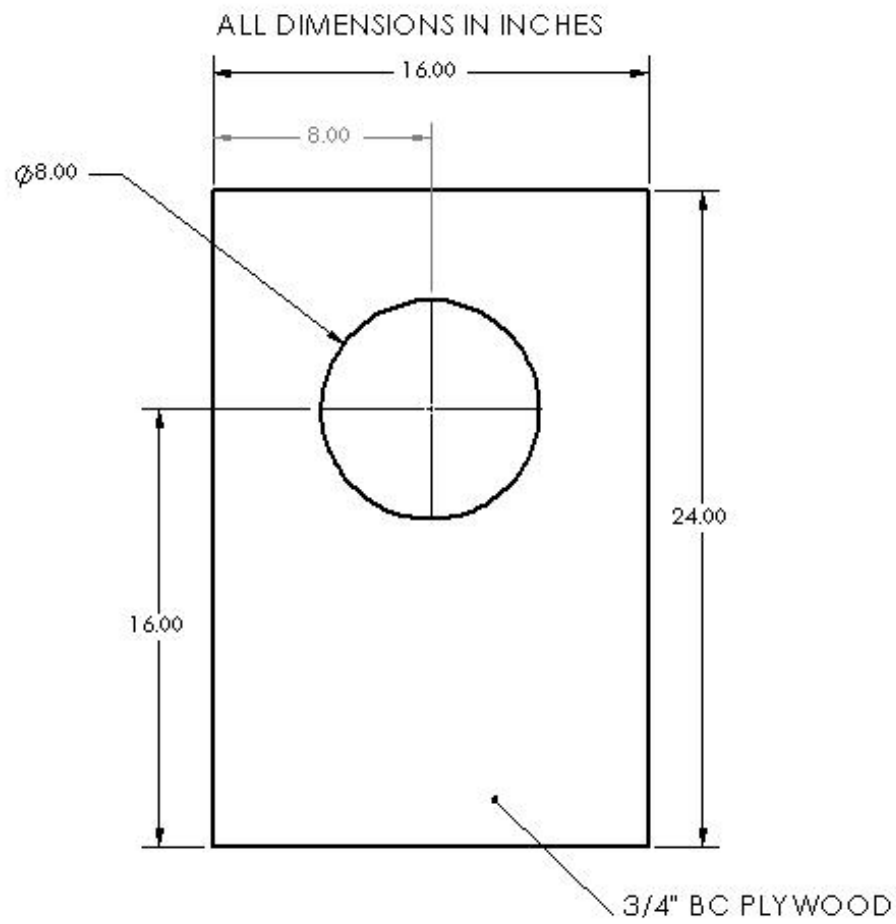

Figure 4: Home Plate (made from white vinyl tape)

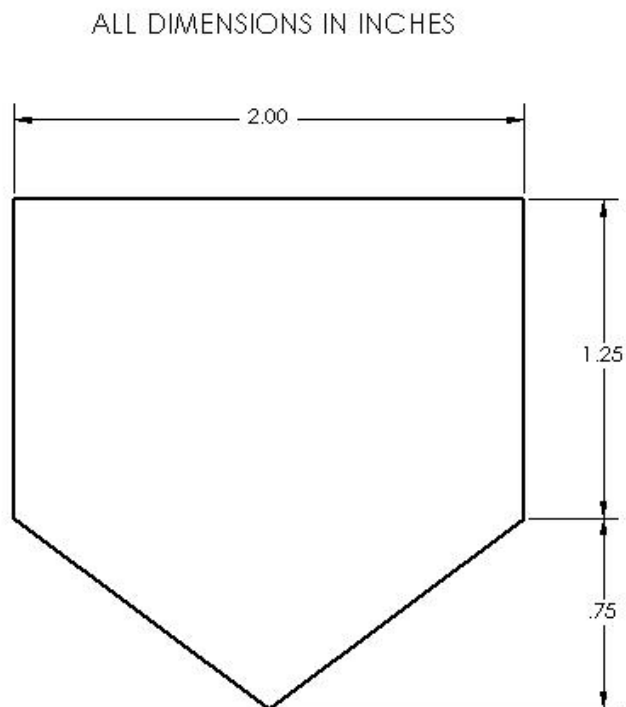

Figure 5: Home Plate Position (Front corners coincident with the outside edges of the tape)

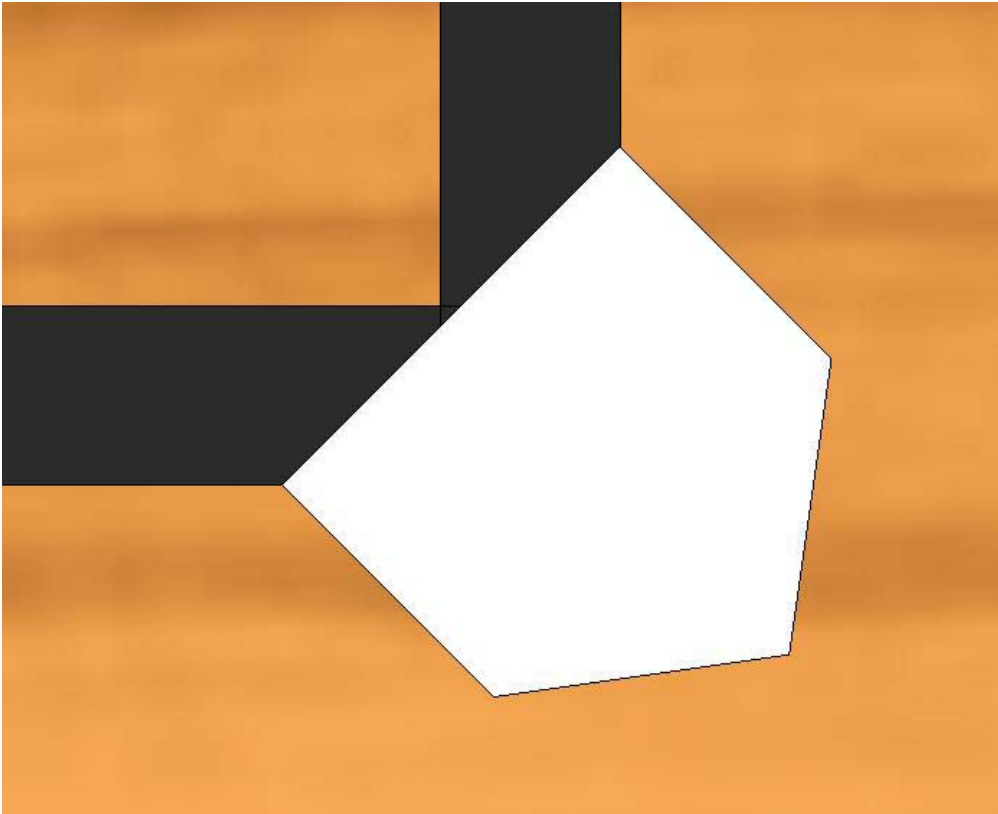
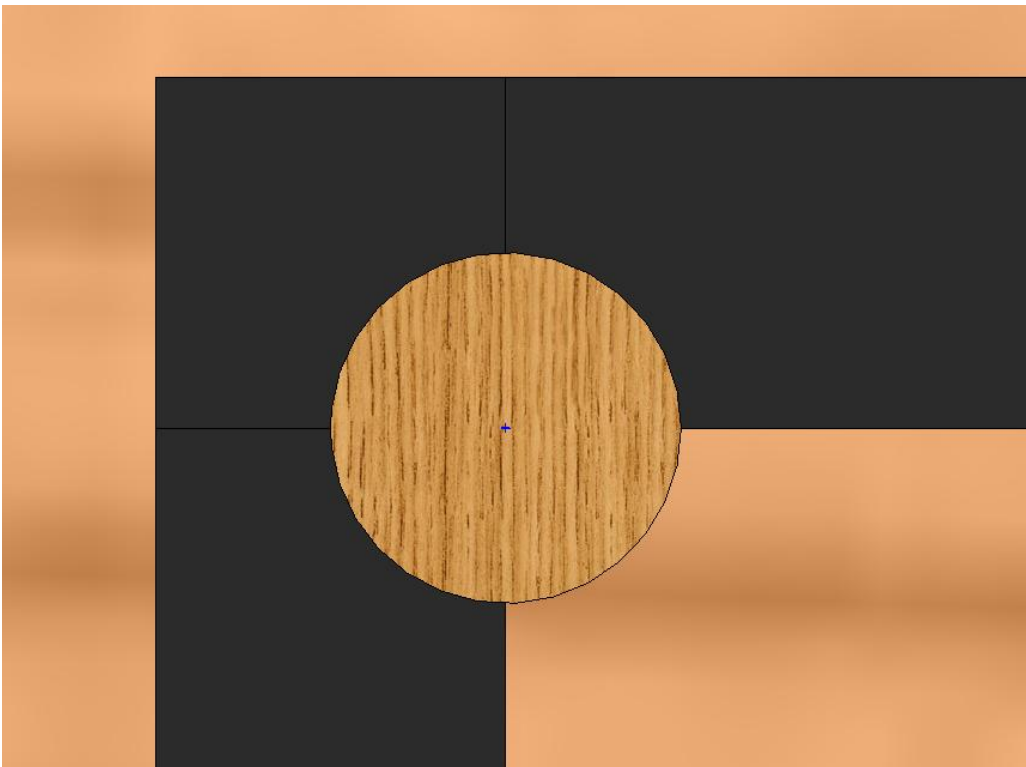

Figure 6: Dowel Positions (Centered on the inside corner of the intersecting tape pieces)



Track Materials:

1. Two 4' X 8' X ¾" sheets BC or better grade plywood.
2. Three 16" X 24" X ¾" pieces of BC or better grade plywood.
3. Two 2" X 4" X 96" boards (actual dimensions 1.5" X 1.5" X 96").
4. Two 2" X 4" X 93" boards (actual dimensions 1.5" X 1.5" X 93").
5. One 2" X 4" X 16" board (actual dimensions 1.5" X 1.5" X 16").
5. Three hardwood dowels with diameters of 0.750" and heights of 3.50".
6. Three, 3-star Stiga Orange Table Tennis balls. These are available from target.com at http://www.target.com/gp/search/185-1767873-1970353?field-keywords=ping_pong_balls&LNM=ping_pong_balls&CPNG=Sports&AFID=google&LID=63567557&ref=tgt_adv_XSGO0782
7. One roll of ¾" wide black vinyl electrical tape for the baselines.
8. One roll of ¾" wide white vinyl electrical tape for home plate.
9. Fasteners or adhesive.
10. Netting material for catching balls that pass through the 8" holes of the targets.
11. 2"x4" boards for constructing a substructure to maintain flatness of the plywood.

Construction Procedures:

1. Place the two sheets of plywood on a flat surface to form the 8' X 8' base for the track.
2. Draw light lines parallel to each edge of the track that are 20" from the edge (see figure 2).
3. Apply black vinyl tape along the baselines so that the outer edge of the lines is coincident with the construction lines drawn in step 2 (see figure 2).
4. Cut two 2 X 4 boards to a length of 93".
5. Fasten two 96" and two 93" 2 X 4 boards along the perimeter of the track so that the outside edge of the 2 X 4 boards are coincident with the outside edge of the plywood.
6. Miter the ends of the 2 X 4 X 16" board at 45 degree angles. Attach this board to the perimeter boards in center field to form an isosceles triangle (see figure 2).
7. Cut the eight inch diameter hole in each of the three 16" X 24" X ¾" pieces of BC grade plywood (see figure 3).
8. Fasten one plywood target to the perimeter board in left field as shown in figures 1 and 2. The bottom edge of the target is coincident with the plywood track. The left edge of the left field target is coincident with the left edge of the left field foul line. The entire target is therefore in fair territory.
9. Fasten one plywood target to the perimeter board in right field as shown in figures 1 and 2. The bottom edge of the target is coincident with the plywood track. The right edge of the right field target is coincident with the right edge of the right field foul line. The entire target is therefore in fair territory.
10. Fasten one plywood target to the 16" mitered board in center field as shown in figures 1 and 2. The bottom edge of the target is coincident with the plywood track. The left and right edges of the center field target should be coincident with the left and right edges of the mitered board respectively.
11. Attach black vinyl tape along the left vertical edge of the left field target to represent the left field foul pole. Note that the foul pole is in fair territory.
12. Attach black vinyl tape along the right vertical edge of the right field target to represent the right field foul pole.
13. Cut pieces of white vinyl tape to form home plate (see figure 4).
14. Affix home plate to the track so that the front edge is parallel to the center field target, the left front corner is coincident with the outer edge of the left field foul line, and the right front corner is coincident with the outer edge of the right field foul line (see figure 5).
15. Trim the black vinyl tape under home plate so that there is only a single layer of tape above the plywood surface.

16. Place the three hardwood dowels on the track in the positions of first, second, and third bases so that the center of the dowels are coincident with the inside corner of the two intersecting pieces of black electrical tape (see figure 6).
17. To provide for maximum flatness a 2"x4" substructure should be constructed and attached to the track.
18. Netting will be added to the back side of the targets to catch balls that pass into the 8" diameter hole in the target. This netting must not cause a ball to rebound out of the hole.

Vehicle Specifications:

Allowable Energy Sources:

Any energy source is allowed as long as it is completely contained within the robot and does not create or emit any gaseous, liquid, or solid materials. Energy sources must not present any safety hazards to participants or spectators. Containers of compressed gases other than air are prohibited.

Maximum Robot Size:

The robot must fit inside a box with vertical sides having inside dimensions of 8.0" X 12.0". There is no height limit.

Before each trial the judges may inspect the robot to insure that the size and placement requirements are met.

During a trial all parts of the robot must remain within the 8.0" X 12.0" size constraint.

Components, Fabrication and Cost:

Team members using materials which are commonly available to the general public must perform all fabrication. Use of commercially available vehicles, robots, or entire kits such as RC cars, Legos, K-nex, Fischer-Technics, Parallax or erector sets may not be used. Individual components from these cars, robots or kits may be integrated into a team's robot as long as the majority of the robot's components are not from the same car, robot, or kit source. The cost of purchasing all components must not exceed \$350.

Robot Navigation:

A trial will be initiated when a team member presses or pulls a button, lever, string, or other starting mechanism on the robot. Energy from the team member's body may not be used to propel the robot or cause components to move on the robot. Once any portion of the robot begins moving, the team members may not touch the robot. The robot must be capable of completing the tasks without any input from the team. Team members may not operate radio, infrared, ultrasonic, electrical, or other remote controls once the robot begins moving.

Static Judging:

During the oral presentation session, each team must have their robot on display for the entire session. The judges will inspect the robots for safety and compliance with the rules. If the judges determine that a robot presents a safety hazard, or has the potential to damage any property or the track, the judges will not allow that robot to run in the testing phase of the competition. If the judges decide that a robot is not in compliance with the intent of the rules, they will assess a penalty to the team that is proportional to the severity of the violation.

Robot Testing:

- 1) A robot must start in a position on the track so that a portion of the robot is either touching or directly above a portion of home plate. In order to score points with the ping pong balls, the robot must either be touching or directly above a portion of home plate.
- 2) Robots may have up to three ping-pong balls stored in them at the start. Additional balls may not be added after the start of a trial. Balls that do not go into the targets may not be removed from the track. Dowels that are knocked down by the balls will be set back up by the judges.
- 3) It is the responsibility of the team to inspect the condition of the track and placement of balls before starting their robot to be certain that everything is in order. Once a robot has been started, the run counts as an official trial and may not be done over.
- 4) A team member will start the robot and judges will begin timing when a signal is received from one of the judges.
- 5) The robot may operate for a maximum of 60 seconds after the judge gives the command to start.
- 6) The trial will end when the robot has knocked down all three dowels in the following order: 1st base, 2nd base, 3rd base, and then touches or passes directly over home plate.
- 7) Each team will be allowed to make four trials. Scoring is described in the section on the next page.
- 8) The order of testing will be determined by random draw (same order used for team presentations). While the preceding team is on the track for a trial, the on-deck team must have their robot on the on-deck table ready to run immediately after the previous team completes their trial. Each team will have one minute to begin a trial after being called. All teams will be called for a trial in a current round before any teams begin the next round of testing.

- 9) Teams may make changes or repairs to their robots between trials but they must be ready within one minute of being called to the track.
- 10) **Teams may not make practice runs during oral presentations or after the start of the robot testing session.**

Robot Testing Scoring:

The goal of the testing is to shoot one ball in each of the 8” diameter holes of the left, center and right field targets and touch all three bases and home plate. The balls may be shot at the targets in any order but the robot must be touching or directly over home plate in order to score points while shooting balls.

Left Field Score:

15 points: A ball passes through the 8” diameter hole in the left field target. No points are awarded for a second or third ball passing through the hole in the left field target.

5 points: If no balls pass through the 8” diameter hole, 5 points will be earned if a ball strikes any part of the left field target. No points are awarded for the second or third balls that strike the left field target.

The Center Field and Right Field Scores are computed the same way as the Left Field Score.

Base Running Score:

The Base Running Score is computed using the formula: (60 – time in seconds to complete the trial)

The Base Running Score may be earned even if no points are earned shooting balls at the targets.

Total Testing Score:

Total Testing Score = Base Running Score + Left Field Score + Center Field Score + Right Field Score

Oral Presentation:

Prior to the testing of the vehicles, each team shall make an oral presentation that is 10 minutes in duration. The judges may reduce the length of the presentations if the number of entries does not allow the presentation component of the competition to be completed in the allotted time. The oral presentation will be followed by questions from the judges. If time allows, the judges may allow additional questions from the audience.

All participants must be present for all presentations. In addition, each team's robot must remain on display in the presentation room for the entire duration of the presentations. **Team members may neither work on, nor test their robots during the oral presentations.** The judges will perform their static judging of the robots during the oral presentations.

The objective of the oral presentation is to describe the engineering design process that a team used to arrive at the final solution. The oral presentations should include the components listed below. Each of the 6 topics is worth 10 points. A perfect score for the oral presentation is 60 points.

1. Problem Identification:

What tasks must the robot perform?

What constraints were present that limited the design choices?

What technical problems had to be solved in order for the robot to perform the required tasks?

2. Preliminary Ideas:

Describe the ideas that were generated for solving the problem.

Where did your design ideas originate?

What criteria were used to narrow the list of possible solutions?

3. Refinement:

What physical, CAD, and/or analytical models were built in order to evaluate the design alternatives?

4. Analysis:

What data and results were obtained from the models?

How did this information help guide the design process toward a final solution?

5. Final Solution:

Display images of the robot, wiring schematics, and flow charts of programs to describe how it works and how it was fabricated. An itemized cost analysis should also be shown.

6. Presentation Quality:

The following items will be evaluated by the judges to determine the quality of each presentation: team appearance, organization, vocal quality, visual aids.

Written Report:

Prior to the oral presentation, each team must present the judges with 5 copies of their written report. The written report should include the components listed below. Each of the 4 topics is worth 10 points. A perfect score for the written report is 30 points.

1. Executive Summary:

This summary should be no more than one page using a 12-point font and single spaced. The summary should succinctly describe the problem that was solved, why the robot is an optimal solution to the problem, results of pre-competition testing, and a summary of the cost of the robot.

2. CAD Images, Circuit Schematics, and Programming Flowcharts:

CAD images should adequately describe the form and function of the robot.

Circuit schematics should convey how the circuitry was constructed and how it works.

If a micro-controller was used, a descriptive flowchart of the programming code should be displayed.

3. Bill of Materials:

The bill of materials should include the following information for each component of the robot: part name, size or part number, vendor name, quantity used, unit price, and total price. You should also sum all the total prices to display the overall cost of the components of your robot. This cost must be less than \$350. For components that you did not have to purchase you must still list a vendor where the item could be purchased along with the unit and total price. These prices must be included in the overall cost of the robot.

4. Sustainability Analysis:

A one page analysis of the materials and processes used to create your robot must be included. In this analysis your team must assess the environmental impact of your project. Some of the items that should be addressed in this analysis are the amount of emissions generated and energy consumed in building your robot and in the manufacture of the raw materials, the amount of new and used materials utilized, and the reusability and recyclability of the components of your robot

Overall Scoring:

The overall score for a team will be equal to the sum of the scores for the oral presentation, written report, and the four time trials. A team will be disqualified from the competition if they fail to make an oral presentation or do not submit a written report.

Overall Score = Time Trial #1 Score + Time Trial #2 Score + Time Trial #3 Score + Time Trial #4 Score + Presentation Score + Written Report Score

Rules Interpretations:

Questions regarding rules prior to the date of the competition should be directed to one of the following:

John Wadach Monroe Community College 1000 E. Henrietta Road Rochester, NY 14623 Phone: 585-292-2488 Email: JWADACH@monroecc.edu	Paul Gordy Tidewater Community College 1700 College Crescent Virginia Beach, VA 23453 Phone: 757-822-7175 Email: PGordy@tcc.edu
--	--

On the date of the competition:

The judges will interpret the intent of the rules and make all decisions. If the judges determine that a team is in violation of the intent of any rule or specification, they will deduct points in proportion to the severity of the violation. All decisions by the judges are final and may not be appealed.

PROJECT TEAM / ENTRY LIMITATIONS:

Each team must have at least one faculty advisor and at least 2 student members but no more than 10 student members. Each team member must primarily be enrolled in freshmen or sophomore level classes. Each school may have up to three teams entered in the competition unless there is space available for additional teams. If a school has more than one entry then each team must represent a unique solution to the design problem.

PROJECT INTEREST AND REGISTRATION FORMS:

Please find the entry forms on a separate page. The Interest Form must be received no later than March 1, 2010. A Registration Form for each model design team must be received no later than June 1, 2010.

ASEE ANNUAL CONVENTION PASSES:

It is not required that student team members or faculty advisors be registered for the ASEE Annual Convention. Passes will be provided for all team members and advisors so that they can enter the conference area and exhibition area on the day of the competition. Details for obtaining passes will be made available a couple of weeks prior to the competition.

COMPETITION TIMELINE:

The specific time and location of the oral presentations and robot testing will be sent to all teams and published in the ASEE Final Program and Proceedings booklet. The overall format of the competition is given below.

Morning: Oral Presentations and Evaluation of Written Reports

Afternoon: Robot Testing and Awards

PRACTICE SESSION:

The official track will be available in the Exhibition Hall for teams to practice on prior to and following the oral presentations. Teams should be considerate and only use the track for brief periods if other teams are waiting to use the track. No practice runs may be made during the oral presentations or after the robot testing has begun.

AWARDS:

First, second, and third-place teams will receive plaques.

SUNY TYESA COMPETITION

The State University of New York Two Year Engineering Science Association (SUNY TYESA) will host a design-build competition on Saturday, May 1, 2010 at the Borough of Manhattan Community College, New York, NY. SUNY TYESA will use the same rules and project as the 2010 ASEE Design Competition. Teams interested in participating in the SUNY TYESA competition should contact Mark Courtney mcourtne@sunydutchess.edu or visit the SUNY TYESA website at: tyesa.org

2010 ASEE Model Design Competition Registration Form

Name of college/university: _____

Team Name: _____

Name of faculty advisor(s): _____

Mailing Address: _____

Phone: _____ Fax: _____

Email (print clearly): _____

Student team captain: _____

Other student team members:

1. _____ 2. _____ 3. _____

4. _____ 5. _____ 6. _____

7. _____ 8. _____ 9. _____

Which students/advisors need badges for the convention center? (Badges are needed if you are not registered for the convention).

Circle one: All need badges. None need badges. Only those listed below need badges.

Please submit this form to : Paul E. Gordy - ASEE TYCD Chair
Tidewater Community College
1700 College Crescent
Virginia Beach, VA 23453
Phone: 757-822-7175
Fax: 757-822-7334
Email: PGordy@tcc.edu

**Return one copy of this form for each team entered by
June 1, 2010 (by US mail , fax, or email)**

2010 ASEE Model Design Competition Interest Form

Name of college/university: _____

Name of faculty advisor(s): _____

Mailing Address: _____

Phone: _____ Fax: _____

Email (print clearly): _____

Number of model entries expected (maximum of 3): _____

Please submit this form to: Paul E. Gordy - ASEE TYCD Chair
Tidewater Community College
1700 College Crescent
Virginia Beach, VA 23453
Phone: 757-822-7175
Fax: 757-822-7334
Email: PGordy@tcc.edu

Return this form by March 1, 2010 (by US mail , fax, or email)