

Inventor Assignment #8

Reading Assignment:

Read Chapter 12 in Parametric Modeling with Autodesk Inventor 2009, by Randy Shih

Computer Assignment:

Complete an **assembly drawing** of the bench shown below. This diagram came from problem 5.114 in Statics, 7th Edition, by Beer & Johnston and the goal of the problem was to find the x and y coordinates of the center of gravity (z is known to be in the middle of the bench by symmetry).

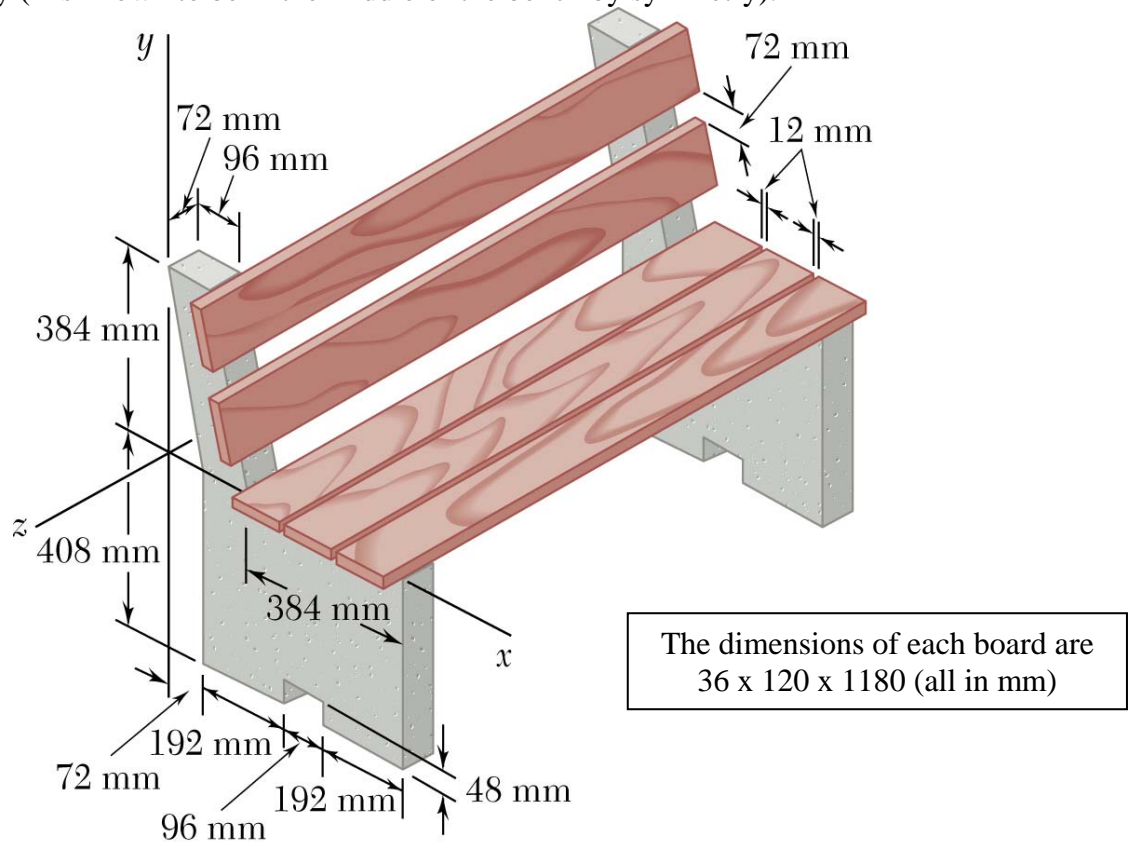

Additional specifications:

1. Create metric parts for the 2 parts in the problem (using a larger grid might be a good idea). Use **Project Geometry – Center Point** to display the origin on each sketch plane. Be sure that the bench support is located in precisely the correct location with respect to the origin as shown in the diagram for the bench. For the boards, locate the origin as indicated in the sketch below.

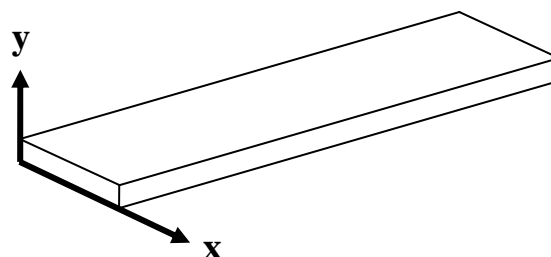

2. Add an additional dimension to the drawing of the bench: Let the boards overhang the bench supports by 72 mm.
3. Create an assembly of the bench using the two parts created above. Be sure to use the left bench support as the **base part** since the original problem shows the (x, y, z) axes oriented on this part and *the origin of the assembly is equal to the origin of the base part*. Add constraints to each part until it cannot move (0 degrees of freedom). Be sure to select **View – Degrees of Freedom** so that you can see degrees of freedom removed as you add each constraint.
4. Change the **iProperties** for each part (from the assembly) to specify the material type. This problem originally called for the bench supports to be made of concrete and the boards to be made of wood. Those materials are not available in Inventor, so use:
 - **welded aluminum** (density 2710 kg/m^3) for the bench supports
 - **ABS plastic** (density 1060 kg/m^3) for the boards
5. Use the clipboard to copy the table shown under the Physical tab for each part and for the entire assembly (3 tables total). Paste the tables into a word processing document and put a border around each table.
6. Add the following information to the top of the word processing document and print the document.
 - your name
 - the course number
 - the assignment number
7. Create a detail drawing for each part using an A-size (portrait) sheet. Show all dimensions. Use good dimensioning style. Include appropriate title block information.
8. Create a drawing for entire bench using an A-size (portrait) sheet. Only an isometric view is required. Add appropriate information to the title block, but no dimensions, balloons, or material lists are required. Add a add a text box in the drawing area with the following information:
 - x-coordinate of center of gravity: (list value with units)
 - y-coordinate of center of gravity: (list value with units)
 - volume: (list value with units)
 - mass: (list value with units)
 - weight: (list value with units of N) (Recall that $W = mg$ and $g = 9.81 \text{ m/s}^2$)
 - weight: (list value with units of lb)
9. Print the detail drawings and the drawing for the assembly. Staple together the assembly drawing, the two detail drawings, and the word processing document with the physical properties and submit them to the instructor.